

---

# ***Quick Guide for V2.5 Packs***

---

## ***Last Updated***

*From Jan 2010, we added external connectors for balance/sense wires between the cells and the BMS like the picture below.*

***Please plug all of the matched pairs together before charging or discharging the battery pack!***

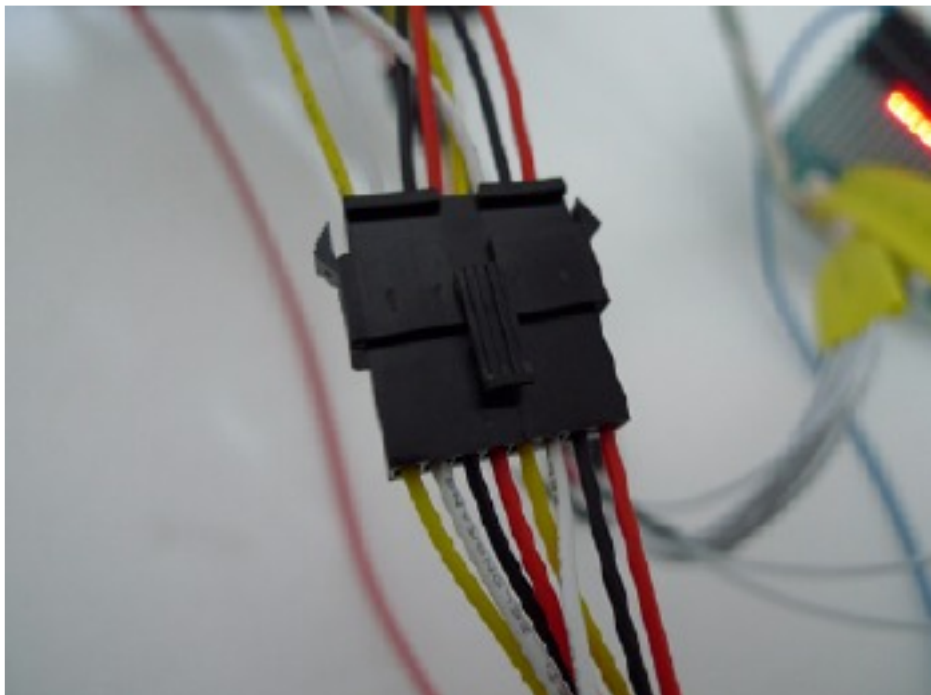
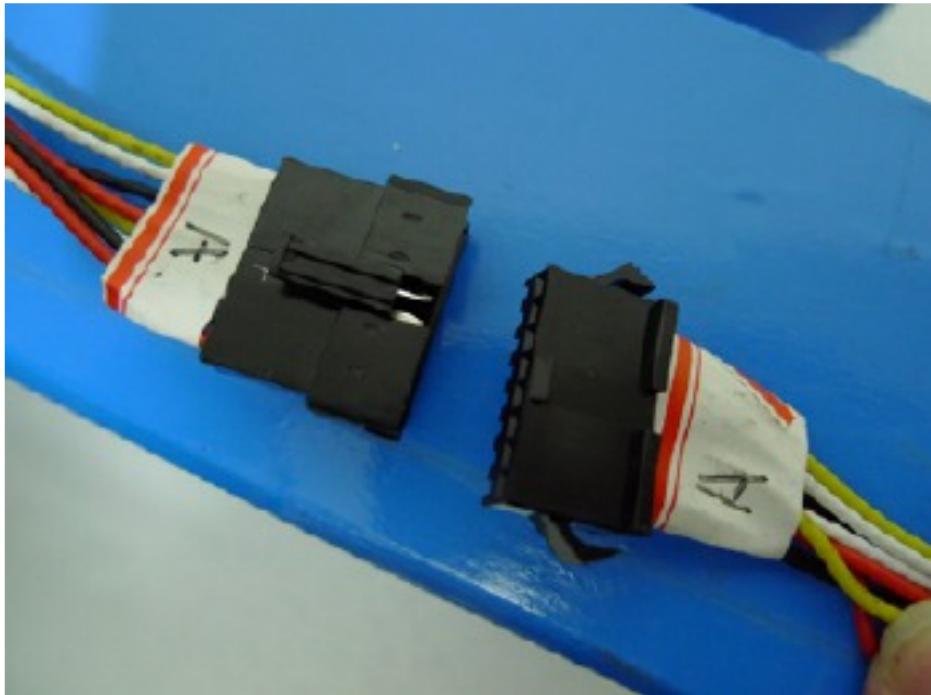

---

## Specification of Charger (2A or 5A)

- **Input Voltage:** AC100-240Volts
- **Output Voltage:** DC61Volts<sub>±</sub>(2%)
- **Output Current:** 2A for 48V , 2.5A for 36V, 3A for 24V<sub>±</sub>(%) or 5A (± 3%)

Before July 2009, we used 3 prong chassis connectors as follows



**Polarity of the Connector (face to the connector):**

1. “+”
2. Empty
3. “-“

From August 2009, we started to use 3 prong XLR connectors as follows



**Polarity of the Connector (face to the connector):**

1. “+”
2. “-“
3. Empty

**Caution:** Please make sure the polarity of the charger connector is corresponding to your battery box or battery pack, positive to charging positive, negative to charging negative. Any mistakes might destroy the battery pack.

### Wiring of Battery Output

- **Large RED Wire :** “+” for discharge
- **Large Black Wire:** “-“ for discharge

- 
- **Small RED Wire:** “+” for charge
  - **Small Blue wire:** “-“ for charge

## Wiring

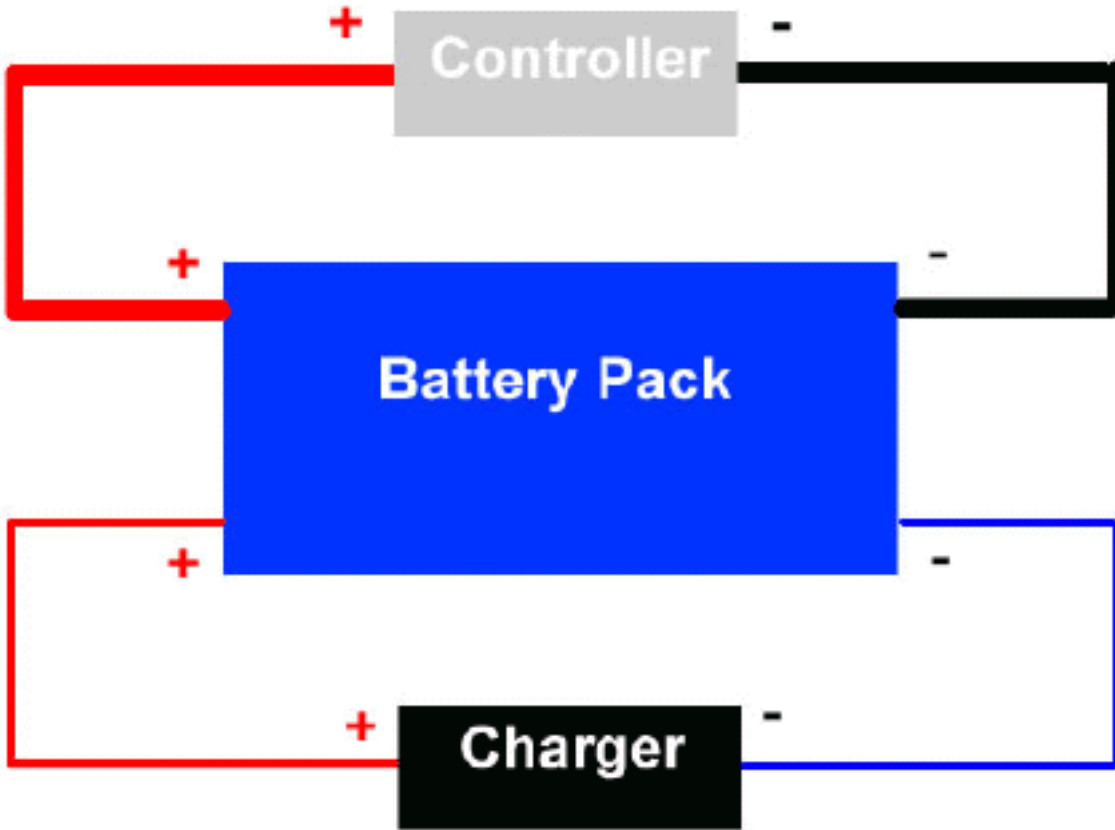

**Caution:** Please be very careful when connecting these wires to your battery box or electric vehicle. If you don't understand how to connect, please send mail to [pingping227@hotmail.com](mailto:pingping227@hotmail.com). Any mistakes in this progress might destroy the battery pack.

## Storage

*If the battery pack won't be used for longer than one month, please charge it before storing it. We recommend to check its voltage at least one time every month. If voltage is*

**Nominal voltages:**

12V pack – 12.8V 24V pack – 25.6V 36V pack – 38.4V  
48V pack – 51.2V 60V pack – 64.0V 72V pack – 76.8V

---

## Balance

*There're some red LEDs (lights) on the BMS.*

**Numbers of red LEDs on the BMS:**

- 12V pack – 4 red LEDs
- 24V pack – 8 red LEDs
- 36V pack – 12 red LEDs
- 48V pack – 16 red LEDs
- 60V pack – 20 red LEDs
- 72V pack – 24 red LEDs

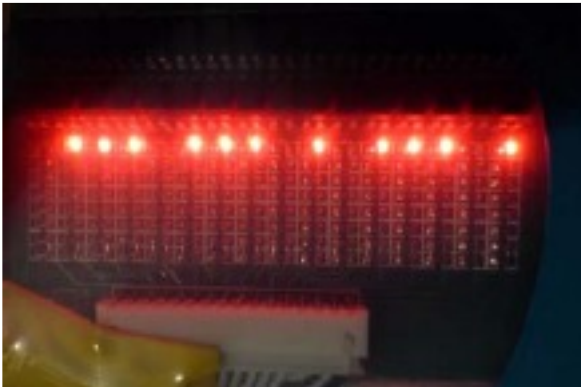
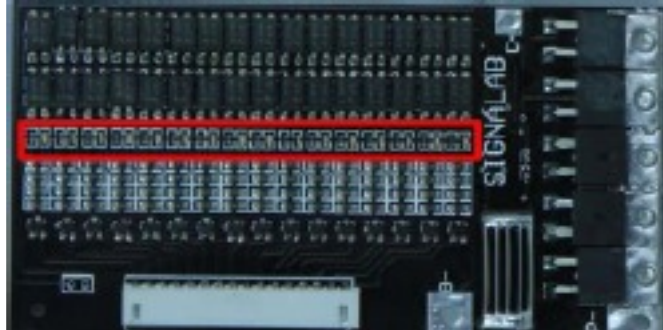

*When the pack is being charged and nearly full, the LEDs on the BMS will light up one by one. They're being balanced.*

*When all of them light up, the pack is fully charged and balanced. After that, if you disconnect the charger, the LEDs could be still on or blinking. That's normal. You don't need to wait for them to be off and can use the pack immediately.*

*Sometimes, one or two LEDs couldn't light up at same time as the rest, because the cells cannot be fully matched. That's also why we need the BMS to balance the cells. If you charge the pack longer, the LED could light up like others. If it doesn't light yet, please just use the pack as usually. If you don't lose any capacity from the pack, please don't worry about the LED. The cell group with the LED could just have higher capacity than the rest.*

## How to connect multiple battery packs in parallel

Diodes need to be added in the circuit to avoid current between the battery packs, because one pack could charge the other if there's voltage difference.

- Current rating of each diode = maximum current of the individual battery pack.

### Connections in parallel

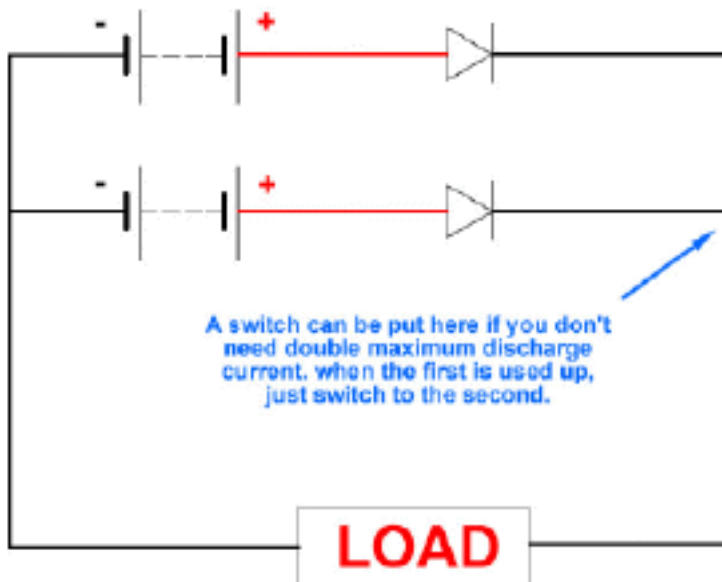

## How to connect multiple battery packs in series

Diodes need to be added in the circuit to protect the BMS

- Voltage rating of each diode = maximum voltage of the battery pack
- Current rating of each diode = maximum current of the system

### Diodes for Packs in Series

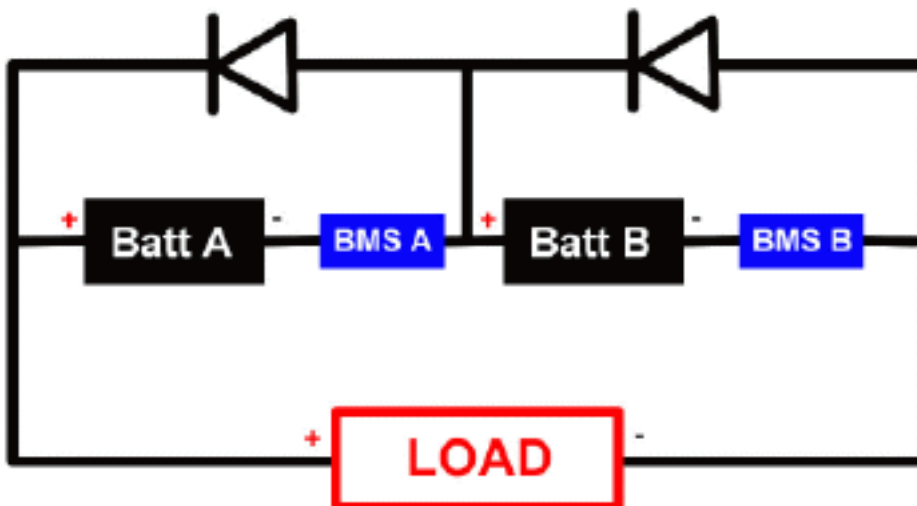

## How to connect a PingBattery to a regenerative controller

Please don't connect the battery pack directly to a controller that has the function of regenerative brake. Please connect them like the diagram below.

### How to connect a PingBattery to a Regen Controller

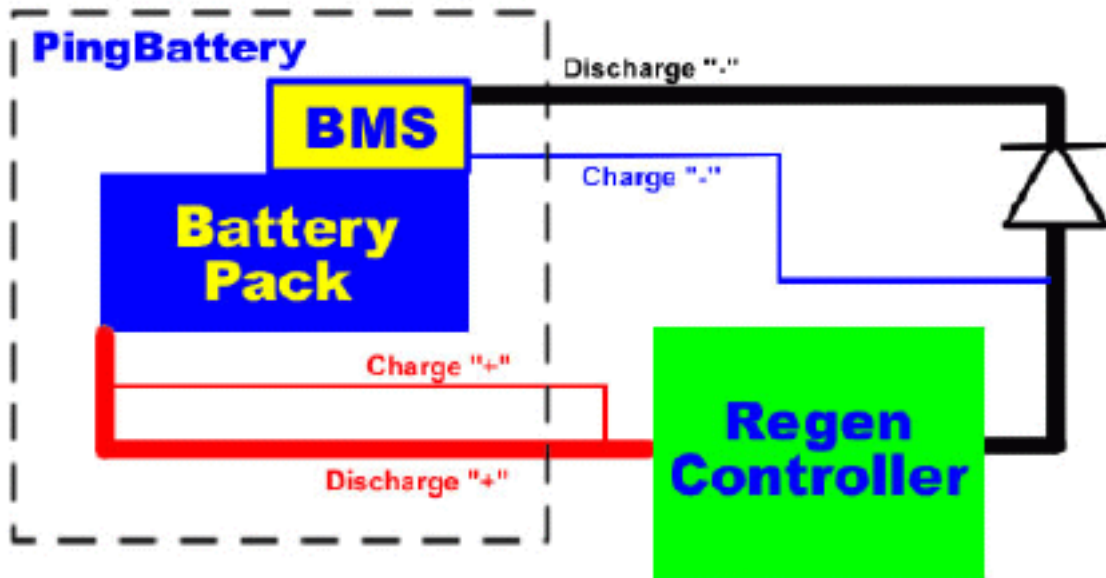

**Regen Current cannot be higher than 5Amps**



*Diode - Rating is higher than the peak discharge current and pack voltage.*

### Tips

- *First charging costs more than 10 hours. Red light of the charger turns to green, then turns to red again after a while, again and again. It's normal. The charger is balancing the capacity of battery cells. If the battery pack works properly, please ignore the light on the charger. You just need to check the LEDs on the BMS to see if the battery pack has been fully charged.*
- *The battery pack's capacity will be activated to its full capacity after 3 to 5 cycles. Before being activated, it seems to have 80% to 90% of its full capacity.*